

CARATTERISTICHE DEI MOTORI SOMMERSI IN ACCIAIO INOX AISI 316

FEATURES OF STAINLESS STEEL AISI 316 SUBMERSIBLE MOTORS

CARACTÉRISTIQUES DES MOTEURS IMMERGÉS EN ACIER INOXYDABLE AISI 316

6F...X



Motore tipo Motor type Type moteur	Potenza nominale Rated power Puissance nominale		η m Rendimento in % Efficiency in % Rendement en %	cos ϕ Fattore di potenza Power factor Facteur de puissance	A MAX Corrente nominale Rated current A Courant Nominal A		Rotazione giri/min Rotation r.p.m. Rotation tours/min.	Max avviamenti/ora Starts/Hour max Max démarrages/heure	Avviamento Starting Démarrage			
	CV HP	kW			230V	400V			Diretto Direct Direct		Stella/ Triangolo Star/Delta Etoile/Triangle	Statorico Statoric Statorique
			Ma/Mn	Ia/In					Ia/In	Ia/In		
6F 3X	3	2,2	79	0,82	10,5	6	2880	10	1,87	4,95	1,2	3,4
6F 5X	5,5	4	79,5	0,83	16	9,5	2880		1,97	5,2	1,3	3,6
6F 7X	7,5	5,5	78	0,87	21,5	12,5	2850		1,80	4,90	1,6	3,4
6F 10X	10	7,5	78,5	0,86	29,5	17	2850		2,06	5,35	1,7	3,7
6F 12X	12,5	9,2	78	0,87	36	21,5	2830		1,99	5,05	1,7	3,5
6F 15X	15	11	79	0,87	42,5	24,5	2840		1,91	5,00	1,6	3,6
6F 17X	17,5	13	80	0,86	51	29	2840		1,91	5,00	1,6	3,6
6F 20X	20	15	81	0,86	60	34	2830		2,21	5,05	1,6	3,5
6F 25X	25	18,5	82	0,85	69,5	40	2845		2,02	4,85	1,6	3,4
6F 30X	30	22	83	0,86	83	48	2845		1,82	4,60	1,5	3,2
6F 35X	35	26	82,5	0,87	95	55	2830		1,70	4,90	1,6	3,4
6F 40X	40	30	83	0,85	113,5	65,5	2840		1,97	5,15	1,7	3,6
6F 50X	50	37	83	0,85	138,5	80	2840		8	1,80	4,75	1,5
6F 60X	60	45	83	0,85	167	96,5	2840	1,85		5,05	1,6	3,4

Motore tipo Motor type Type moteur	L mm mt	Lunghezza cavo Cable length - Longueur cable	Sezione mm ² Cross section mm ² - Section mm ²				Montaggio orizzontale Horizontal installation Installation horizontale	Temperatura max. dell'acqua in °C Max. water temperature in °C Température maxi. de l'eau en °C	Carico assiale Axial load - Charge Axial	Peso Weight - Poids	
			Avviamento Starting - Démarrage								
			Diretto Direct - Direct		Stella/Triangolo Star/Delta Etoile/Triangle						
			230 V	400 V	230/400 V	400/690 V					
6F 3X	640	3,5	(1x4)x3	(1x4)x3	(1x4)x6	(1x4)x6	S	30	55	18000	42
6F 5X	670										45
6F 7X	700										47
6F 10X	740										51
6F 12X	770										55
6F 15X	840										62
6F 17X	840										63
6F 20X	900										69
6F 25X	970										76
6F 30X	1040										83
6F 35X	1100										90
6F 40X	1240										104
6F 50X	1370										117
6F 60X	1400	122									

Sezione Section Section	(mm ²)	(mm)
1 x 4	7,5	
1 x 6	8	
1 x 10	9	
1 x 16	10,5	
1 x 25	12,5	

Ma = Coppia di avviamento Starting torque Couple au démarrage
Mn = Coppia nominale Nominal couple Couple nominale
Ia = Corrente di avviamento Starting current Intensité au démarrage
In = Corrente nominale Nominal current Intensité nominale

S = Si - Yes - Oui N = No - No - No ES = Esecuzione speciale - Special execution - Execution spéciale



6F...XD

CARATTERISTICHE DEI MOTORI SOMMERSI IN ACCIAIO INOX DUPLEX

FEATURES OF STAINLESS STEEL DUPLEX SUBMERSIBLE MOTORS

CARACTÉRISTIQUES DES MOTEURS IMMERGÉS EN ACIER INOXYDABLE DUPLEX

Motore tipo Motor type Type moteur	Potenza nominale Rated power Puissance nominale		η m Rendimento in % Efficiency in % Rendement en %	cos ϕ Fattore di potenza Power factor Facteur de puissance	A MAX Corrente nominale Rated current A Courant Nominal A		Rotazione giri/min Rotation r.p.m. Rotation tours/min.	Max avviamenti/ora Starts/Hour max Max démarrages/heure	Avviamento Starting Démarrage			
	CV HP	KW			230V	400V			Diretto Direct Direct		Stella/ Triangolo Star/Delta Etoile/Triangle	Statorico Statoric Statorique
			Ma/Mn	Ia/In					Ia/In	Ia/In		
6F 3XD	3	2,2	79	0,82	10,5	6	2880	10	1,87	4,95	1,2	3,4
6F 5XD	5,5	4	79,5	0,83	16	9,5	2880		1,97	5,2	1,3	3,6
6F 7XD	7,5	5,5	78	0,87	21,5	12,5	2850		1,80	4,90	1,6	3,4
6F 10XD	10	7,5	78,5	0,86	29,5	17	2850		2,06	5,35	1,7	3,7
6F 12XD	12,5	9,2	78	0,86	36	21,5	2830		1,99	5,05	1,7	3,5
6F 15XD	15	11	79	0,87	42,5	24,5	2840		1,91	5,00	1,6	3,6
6F 17XD	17,5	13	80	0,86	51	29	2840		1,91	5,00	1,6	3,6
6F 20XD	20	15	81	0,86	60	34	2830		2,21	5,05	1,6	3,5
6F 25XD	25	18,5	82	0,85	69,5	40	2845		2,02	4,85	1,6	3,4
6F 30XD	30	22	83	0,86	83	48	2845		1,82	4,60	1,5	3,2
6F 35XD	35	26	82,5	0,87	95	55	2830		1,70	4,90	1,6	3,4
6F 40XD	40	30	83	0,85	113,5	65,5	2840		1,97	5,15	1,7	3,6
6F 50XD	50	37	83	0,85	138,5	80	2840	8	1,80	4,75	1,5	3,3
6F 60XD	60	45	83	0,85	167	96,5	2840		1,85	5,05	1,6	3,4

Motore tipo Motor type Type moteur	L mm mt	Lunghezza cavo Cable length - Longueur cable	Sezione mm ² Cross section mm ² - Section mm ²				Montaggio orizzontale Horizontal installation Installation horizontale	Temperatura max. dell'acqua in °C Max. water temperature in °C Température maxi. de l'eau en °C		Carico assiale Axial load - Charge Axial	Peso Weight - Poids
			Avviamento Starting - Démarrage					PVC	PE2+PA		
			Diretto Direct - Direct		Stella/Triangolo Star/Delta Etoile/Triangle						
			230 V	400 V	230/400 V	400/690 V					
6F 3XD	640	3,5	(1x4)x3	(1x4)x3	(1x4)x6	(1x4)x6	S	30	55	18000	42
6F 5XD	670										45
6F 7XD	700										47
6F 10XD	740										51
6F 12XD	770										55
6F 15XD	840										62
6F 17XD	840										63
6F 20XD	900										69
6F 25XD	970										76
6F 30XD	1040										83
6F 35XD	1100										90
6F 40XD	1240										104
6F 50XD	1370	117									
6F 60XD	1400	122									

Sezione Section Section	(mm ²)	(mm)
1 x 4	7,5	
1 x 6	8	
1 x 10	9	
1 x 16	10,5	
1 x 25	12,5	

Ma = Coppia di avviamento / Starting torque / Couple au démarrage
 Mn = Coppia nominale / Nominal couple / Couple nominale
 Ia = Corrente di avviamento / Starting current / Intensité au démarrage
 In = Corrente nominale / Nominal current / Intensité nominale

S = Sì - Yes - Oui N = No - No - No ES = Esecuzione speciale - Special execution - Execution spéciale

CARATTERISTICHE DEI MOTORI SOMMERSI IN ACCIAIO INOX AISI 316

FEATURES OF STAINLESS STEEL AISI 316 SUBMERSIBLE MOTORS

CARACTÉRISTIQUES DES MOTEURS IMMERGÉS EN ACIER INOXYDABLE AISI 316

8F...X



Motore tipo Motor type Type moteur	Potenza nominale Rated power Puissance nominale		η m Rendimento in % Efficiency in % Rendement en %	cos ϕ Fattore di potenza Power factor Facteur de puissance	A MAX Corrente nominale Rated current A Courant Nominal A		Rotazione giri/min Rotation r.p.m. Rotation tours/min.	Max avviamenti/ora Starts/Hour max Max démarrages/heure	Avviamento Starting Démarrage				
	CV HP	kW			4/4	4/4			230V	400V	Diretto Direct Direct		Stella/ Triangolo Star/Delta Etoile/Triangle
			Ma/Mn	Ia/In							Ia/In	Ia/In	
8F 30X	30	22	83,4	0,85	81,5	47	2880	10	1,88	4,80	1,6	3,3	
8F 40X	40	30	84	0,87	110	63,5	2880		1,83	4,95	1,6	3,4	
8F 50X	50	37	85	0,88	130	75	2915		1,76	5,27	1,7	3,7	
8F 60X	60	45	86	0,89	155	89,5	2880	8	1,88	5,45	1,8	3,8	
8F 70X	70	51	86	0,88	183	106	2880		1,78	5,50	1,8	3,8	
8F 75X	75	55	87	0,90	197	114	2860		1,88	5,50	1,8	3,8	
8F 80X	80	59	87	0,86	205	118	2920		1,89	5,55	1,8	3,9	
8F 85X	85	62	86,5	0,87	222	128	2920		1,87	5,53	1,8	3,8	
8F 90X	90	66	86,7	0,87	230	133	2900		1,86	5,50	1,9	3,8	
8F 100X	100	75	87	0,87	268	155	2880		1,90	5,65	1,9	3,9	
8F 125X	125	92	86	0,87	/	190	2890	6	1,85	5,40	/	3,8	
8F 150X	150	110	84	0,88	/	220	2900		1,83	5,35	/	3,8	

Motore tipo Motor type Type moteur	L mm mt	Lunghezza cavo Cable-length - Longueur cable	Sezione mm ² Cross section mm ² - Section mm ²				Montaggio orizzontale Horizontal installation Installation horizontale	Temperatura max. dell'acqua in °C Max. water temperature in °C Température maxi. de l'eau en °C		Carico assiale Axial load - Charge Axial	Peso Weight - Poids
			Avviamento Starting - Démarrage					PVC	PE2+PA		
			Diretto Direct - Direct		Stella/Triangolo Star/Delta Etoile/Triangle						
			230 V	400 V	230/400 V	400/690 V		Kg.			
8F 30X	1080	3,5	(1x16)x3	(1x16)x3	(1x16)x6	(1x16)x6	S	30	55	45000	134
8F 40X	1150										140
8F 50X	1220										155
8F 60X	1330										173
8F 70X	1330		175								
8F 75X	1450		186								
8F 80X	1450		186								
8F 85X	1450		186								
8F 90X	1520	4,5	(1x25)x3	(1x25)x6	(1x25)x6	ES	/	45	60000	207	
8F 100X	1710									238	
8F 125X	1780									240	
8F 150X	1890	/	/	/	(1x25)x6	N	/	45	60000	267	

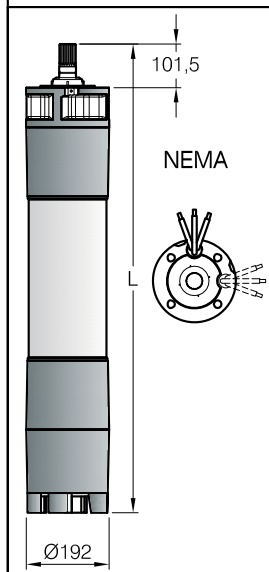

Sezione Section Section	(mm ²) (mm)
1 x 4	7,5
1 x 6	8
1 x 10	9
1 x 16	10,5
1 x 25	12,5

Ma = Coppia di avviamento Starting torque Couple au démarrage
Mn = Coppia nominale Nominal couple Couple nominale
Ia = Corrente di avviamento Starting current Intensité au démarrage
In = Corrente nominale Nominal current Intensité nominale

S = Sì - Yes - Oui N = No - No - No ES = Esecuzione speciale - Special execution - Execution spéciale



8F...XD

CARATTERISTICHE DEI MOTORI SOMMERSI IN ACCIAIO INOX DUPLEX

FEATURES OF STAINLESS STEEL DUPLEX SUBMERSIBLE MOTORS

CARACTÉRISTIQUES DES MOTEURS IMMERGÉS EN ACIER INOXYDABLE DUPLEX

Motore tipo Motor type Type moteur	Potenza nominale Rated power Puissance nominale		η m Rendimento in % Efficiency in % Rendement en %	$\cos\phi$ Fattore di potenza Power factor Facteur de puissance	A MAX Corrente nominale Rated current A Courant Nominal A		Rotazione giri/min Rotation r.p.m. Rotation tours/min.	Max avviamenti/ora Starts/Hour max Max démarrages/heure	Avviamento Starting Démarrage			
	CV HP	kW			4/4	4/4			230V	400V	Diretto Direct Direct	
			Ma/Mn	Ia/In							Ia/In	Ia/In
8F 30XD	30	22	83,4	0,85	81,5	47	2880	10	1,88	4,80	1,6	3,3
8F 40XD	40	30	84	0,87	110	63,5	2880		1,83	4,95	1,6	3,4
8F 50XD	50	37	85	0,88	130	75	2915		1,76	5,27	1,7	3,7
8F 60XD	60	45	86	0,89	155	89,5	2880	8	1,88	5,45	1,8	3,8
8F 70XD	70	51	86	0,88	183	106	2880		1,78	5,50	1,8	3,8
8F 75XD	75	55	87	0,90	197	114	2860		1,88	5,50	1,8	3,8
8F 80XD	80	59	87	0,86	205	118	2920		1,89	5,55	1,8	3,9
8F 85XD	85	62	86,5	0,87	222	128	2920		1,87	5,53	1,8	3,8
8F 90XD	90	66	86,7	0,87	230	133	2900		1,86	5,50	1,9	3,8
8F 100XD	100	75	87	0,87	268	155	2880		1,90	5,65	1,9	3,9
8F 125XD	125	92	86	0,87	/	190	2890	6	1,85	5,40	/	3,8
8F 150XD	150	110	84	0,88	/	220	2900		1,83	5,35	/	3,8

Motore tipo Motor type Type moteur	L mm mt	Lunghezza cavo Cable-length - Longueur cable	Sezione mm ² Cross section mm ² - Section mm ²				Montaggio orizzontale Horizontal installation Installation horizontale	Temperatura max. dell'acqua in °C Max. water temperature in °C Température maxi. de l'eau en °C		Carico assiale Axial load - Charge Axial N	Peso Weight - Poids Kg.
			Avviamento Starting - Démarrage					PVC	PE2+PA		
			Diretto Direct - Direct		Stella/Triangolo Star/Delta Etoile/Triangle						
			230 V	400 V	230/400 V	400/690 V					
8F 30XD	1080	3,5	(1x16)x3	(1x16)x3	(1x16)x6	(1x16)x6	S	30	55	45000	134
8F 40XD	1150										140
8F 50XD	1220										155
8F 60XD	1330										173
8F 70XD	1330										175
8F 75XD	1450										186
8F 80XD	1450										186
8F 85XD	1450										186
8F 90XD	1520										207
8F 100XD	1710										4,5
8F 125XD	1780	240									
8F 150XD	1890	267									

Sezione Section Section	(mm ²)	(mm)
1 x 4	7,5	
1 x 6	8	
1 x 10	9	
1 x 16	10,5	
1 x 25	12,5	

Ma = Coppia di avviamento Starting torque Couple au démarrage	Mn = Coppia nominale Nominal couple Couple nominale	Ia = Corrente di avviamento Starting current Intensité au démarrage	In = Corrente nominale Nominal current Intensité nominale
---	---	---	---

S = Sì - Yes - Oui	N = No - No - No	ES = Esecuzione speciale - Special execution - Execution spéciale
--------------------	------------------	---

CARATTERISTICHE DEI MOTORI SOMMERSI IN ACCIAIO INOX AISI 316

FEATURES OF STAINLESS STEEL AISI 316 SUBMERSIBLE MOTORS

CARACTÉRISTIQUES DES MOTEURS IMMERGÉS EN ACIER INOXYDABLE AISI 316

10F...X



Motore tipo Motor type Type moteur	Potenza nominale Rated power Puissance nominale		η m Rendimento in % Efficiency in % Rendement en %	$\cos\phi$ Fattore di potenza Power factor Facteur de puissance	A MAX Corrente nominale Rated current A Courant Nominal A	Rotazione giri/min Rotation r.p.m. Rotation tours/min.	Max avviamenti/ora Starts/Hour max Max démarrages/heure	Avviamento Starting Démarrage			
	CV HP	kW	4/4	4/4	400V			Diretto Direct Direct		Stella/ Triangolo Star/Delta Etoile/Triangle	Statorico Statorique
								Ma/Mn	Ia/In	Ia/In	Ia/In
10F 80X	80	59	85	0,83	116	2910	8	1,88	4,80	1,6	3,3
10F 100X	100	75	86	0,84	145	2910		1,83	4,95	1,7	3,4
10F 125X	125	92	87	0,87	176	2900		1,76	5,27	1,7	3,7
10F 150X	150	110	87	0,86	210	2870	6	1,88	5,45	1,8	3,8
10F 180X	180	132	87,5	0,87	255	2910		1,78	5,50	1,8	3,8
10F 200X	200	150	88	0,85	290	2920		1,88	5,50	1,9	3,8
10F 230X	230	170	88	0,85	330	2910		1,89	5,55	1,9	3,9
10F 260X	260	190	88	0,84	375	2910		1,87	5,53	1,9	3,9

Motore tipo Motor type Type moteur	L mm	Lunghezza cavo Cable-length Longueur cable mt	Sezione mm ² Cross section mm ² - Section mm ²		Avviamento Starting - Démarrage	Montaggio orizzontale Horizontal installation Installation horizontale	Temperatura max. dell'acqua in °C Max. water temperature in °C Température maxi. de l'eau en °C		Carico assiale Axial load Charge Axial N	Peso Weight - Poids Kg.
			Diretto Direct - Direct	Stella/Triangolo Star/Delta Etoile/Triangle			PVC	PE2+PA		
			400 V	400/690 V			25	45		
10F 80X	1420	3,5	(1x25)x3	(1x25)x6	S	25	45	60000	267	
10F 100X	1540									
10F 125X	1670									
10F 150X	1810	4,5	(1x50)x3	(1x35)x6	ES	25	45	60000	394	
10F 180X	1910									
10F 200X	2030									
10F 230X	2130									
10F 260X	2230									
			(1x70)x3	(1x50)x6	N	/			421	
			(1x95)x3	(1x50)x6	N	/			490	
									530	

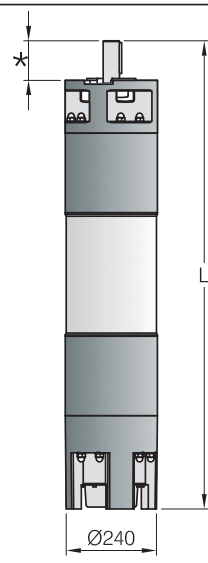

Sezione Section Section	
(mm ²)	(mm)
1 x 25	12,5
1 x 35	13,5
1 x 50	17
1 x 70	19
1 x 95	22,5

* = Vedi scheda accoppiamenti 10"

See technical file 10" couplings

Voir fiche technique accouplements 10"

Ma = Coppia di avviamento Starting torque Couple au démarrage
Mn = Coppia nominale Nominal couple Couple nominale
Ia = Corrente di avviamento Starting current Intensité au démarrage
In = Corrente nominale Nominal current Intensité nominale

S = Sì - Yes - Oui N = No - No - No ES = Esecuzione speciale - Special execution - Execution spéciale



CARATTERISTICHE DEI MOTORI SOMMERSI IN ACCIAIO INOX DUPLEX

10F...XD

FEATURES OF STAINLESS STEEL DUPLEX SUBMERSIBLE MOTORS

CARACTÉRISTIQUES DES MOTEURS IMMERGÉS EN ACIER INOXYDABLE DUPLEX

Motore tipo Motor type Type moteur	Potenza nominale Rated power Puissance nominale		η m Rendimento in % Efficiency in % Rendement en %	cos ϕ Fattore di potenza Power factor Facteur de puissance	A MAX Corrente nominale Rated current A Courant Nominal A	Rotazione giri/min Rotation r.p.m. Rotation tours/min.	Max avviamenti/ora Starts/Hour max Max démarrages/heure	Avviamento Starting Démarrage			
	CV HP	kW						Diretto Direct Direct		Stella/ Triangolo Star/Delta Etoile/Triangle	Statorico Statoric Statorique
			Ma/Mn	Ia/In	Ia/In			Ia/In			
10F 80XD	80	59	85	0,83	116	2910	8	1,88	4,80	1,6	3,3
10F 100XD	100	75	86	0,84	145	2910		1,83	4,95	1,7	3,4
10F 125XD	125	92	87	0,87	176	2900	6	1,76	5,27	1,7	3,7
10F 150XD	150	110	87	0,86	210	2870		1,88	5,45	1,8	3,8
10F 180XD	180	132	87,5	0,87	255	2910		1,78	5,50	1,8	3,8
10F 200XD	200	150	88	0,85	290	2920		1,88	5,50	1,9	3,8
10F 230XD	230	170	88	0,85	330	2910		1,89	5,55	1,9	3,9
10F 260XD	260	190	88	0,84	375	2910		1,87	5,53	1,9	3,9

Motore tipo Motor type Type moteur	L mm	Lunghezza cavo Cable-length Longueur cable mt	Sezione mm ² Cross section mm ² - Section mm ²		Montaggio orizzontale Horizontal installation Installation horizontale	Temperatura max. dell'acqua in °C Max. water temperature in °C Température maxi. de l'eau en °C		Carico assiale Axial load Charge Axial N	Peso Weight - Poids Kg.	
			Avviamento Starting - Démarrage			PVC	PE2+PA			
			Diretto Direct - Direct	Stella/Triangolo Star/Delta Etoile/Triangle						
10F 80XD	1420	3,5	(1x25)x3	400 V	400/690 V	S	25	45	60000	267
10F 100XD	1540									305
10F 125XD	1670									348
10F 150XD	1810	4,5	(1x50)x3	400 V	400/690 V	ES	25	45	60000	394
10F 180XD	1910									421
10F 200XD	2030									450
10F 230XD	2130	4,5	(1x70)x3	400 V	400/690 V	N	/	/	/	490
10F 260XD	2230									(1x95)x3

Sezione Section Section	
(mm ²)	(mm)
1 x 25	12,5
1 x 35	13,5
1 x 50	17
1 x 70	19
1 x 95	22,5

* = Vedi scheda accoppiamenti 10"
See technical file 10" couplings
Voir fiche technique accouplements 10"

Ma = Coppia di avviamento Starting torque Couple au démarrage
Mn = Coppia nominale Nominal couple Couple nominale
Ia = Corrente di avviamento Starting current Intensité au démarrage
In = Corrente nominale Nominal current Intensité nominale

S = Sì - Yes - Oui N = No - No - No ES = Esecuzione speciale - Special execution - Execution spéciale



J

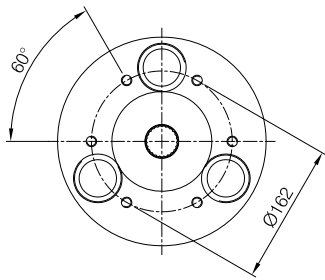
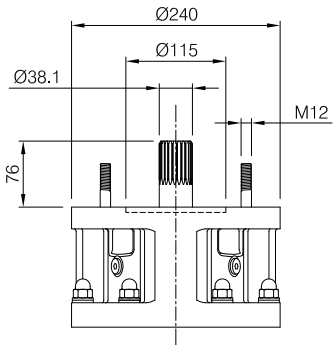

AN

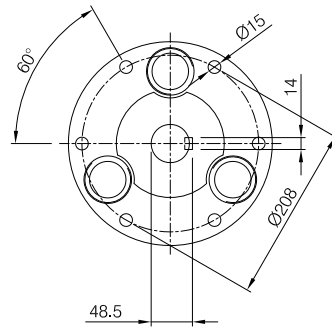
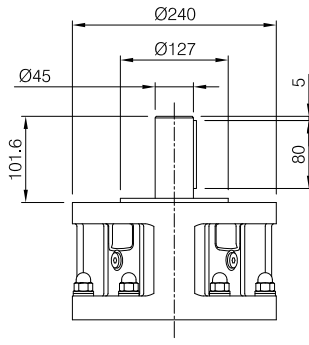

AH

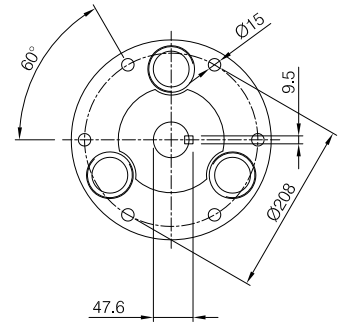
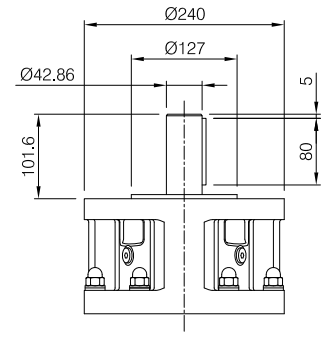

F

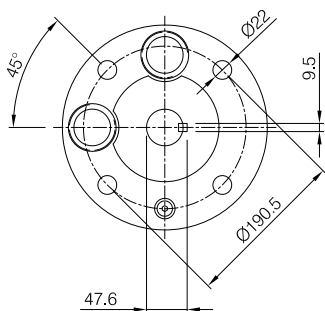
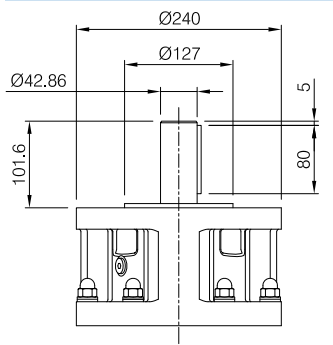

G

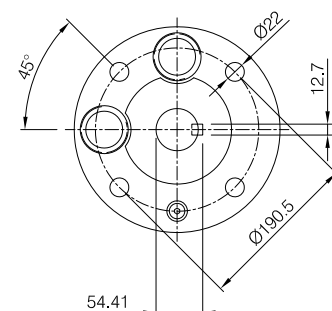
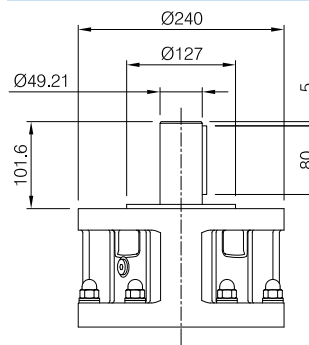

8" NEMA

