

6" High Efficiency System



Franklin Electric
HIGH EFFICIENCY SYSTEM



QUALITY



AVAILABILITY



SERVICE



INNOVATION

Quality in the Well

Table of contents

6" High Efficiency System and High Efficiency Solar System

System	4 - 8
Motor	9 - 13
Variable Speed Drive (VFD)	14 - 15
du/dt Filter	16
Sinus Filter	17
SS Pump	18

Accessories

Lead Termination Kit	19
Motor Filling Liquid	19
Motor Check and Filling Kit	19
Motor / pump Coupling 6"	20
PT100	21
Flow Paddle Switch	21
Level Switch	21
DC Disconnect	21

6" High Efficiency System

Quality in the Well

In consideration of environmental relief and energy saving Franklin Electric developed a High Efficiency 6" Submersible Borehole System, consisting of a synchronous submersible 304SS NEMA motor associated variable frequency drive and output filter.



System Product advantages:

- One-stop shop – perfectly matching components guarantee first class performance
- Up to **20% energy saving***
 - ⇒ *System payback < 2 years*
- Up to **13% improved motor efficiency** (system up to 11%) with excellent partial load behaviour*
 - ⇒ *SKU Reduction*
- Significant lower motor heat rise
 - ⇒ *Increased lifetime*
- Higher power density*
 - ⇒ *Lightweight*
- Easy set-up due to tailored pre-setting, user interface and own **Franklin Electric software**
- Speed control
 - ⇒ *Optimum aggregate operation - pump matches system any time*
- Incorporated Soft start and protection features
 - ⇒ *Increased lifetime*
 - ⇒ *No additional investment*
- Reduced amps
 - ⇒ *Smaller drop lead cross size*
- Top class protection with Electronics in IP66/54**
 - ⇒ *Easy retrofit - no additional cabinet cost*
- Power factor corrected input
 - ⇒ *No power compensation needed*
- Communication Modbus (RS485 and Ethernet)

System Technical Specification:

- Rating: 4 - 37kW
- Power Supply: Voltage 400V +/- 10%
Frequency 50Hz +/- 6%

*In comparison to current asynchronous technology

**Alternative Electronics in IP21/00 for cabinet assembly available

Model Numbers

400V-50Hz / 460V/60Hz High Efficiency System (304SS Motor, VFD & Filter)

P _N [kW]	For panel mount - VFD IP21 & Filter IP00		For wall mount - VFD IP66 & Filter IP54	
	du/dt Filter	Sinus Filter	du/dt Filter	Sinus Filter
4,0	308 010 016*	308 010 116*	308 010 216*	308 010 316*
5,5				
7,5				
9,3	308 014 023	308 014 123*	308 014 223	308 014 323*
11				
13	308 014 038	308 014 131*	308 014 238	308 014 338*
15		308 014 138*		
18,5		308 016 146*		
22	308 016 061	308 016 161*	308 016 261	308 016 361*
26		308 016 187*		
30				
37	308 016 087*	308 016 187*		

*Non-stock items

For lead length > 120m please consult Franklin Electric

System Options:

- Plug-in card 6x DI/DO - 308 170 201
- Plug-in card PT100 - 308 170 202
- Plug-in card Profibus - 308 170 203
- Plug-in card 1x AI & 2x AO 308 170 206
- Power Supply: 200V & 500V
- Sinus output filters in IP54 and IP00
- PT100 protection
- Motors in 316SS and 904L

To find the right System please use Selection & Payback link on: www.franklinwater.eu

Control modes and necessary sensor technologies

Process reference	Control reference	Flow meter	Pressure sensor	Level sensor	PT100 sensor & Drive slot card	Flow switch (digital)
Q - Flow	No (Optional)	mandatory			Optional	
	P	mandatory	mandatory			
	H	mandatory		mandatory		
P - pressure	No (Optional)	Yes*	mandatory		Optional	
	Q	mandatory	mandatory			
	H		mandatory	mandatory		
H - level	No (Optional)	Yes*		mandatory	Optional	
	Q	mandatory		mandatory		
	P		mandatory	mandatory		
Direct Mode	No	Yes**	No	No	Optional	No
Manual Mode	No				Yes*	
Solar	No				Yes*	mandatory

*please consult Franklin Electric

** need to be evaluated to PLC

6" High Efficiency Solar System

Quality in the Well

Franklin Electric is pleased to announce the introduction of the extended SOLAR feature for its 6" High Efficiency Submersible Borehole systems (HES).

These systems, consisting of a full stainless, synchronous submersible NEMA motor associated with a variable frequency drive and matching output filter have proven their world-class efficiency in over 300 applications to date, saving up to 20% of electrical energy when compared to standard synchronous motor systems.



System Product advantages:

- One-stop shop – perfectly matching components guarantee first class performance / efficiency
 - ⇒ *Less panels, more water respectively*
- Direct DC feeding
- Special MPP algorithm for centrifugal borehole pumps
- Top class protection with Electronics in IP66/54
 - ⇒ *No cabinet - no cooling fan/ dust filter - no maintenance*
- GORE® vent
 - ⇒ *No condensation*
- Easy set-up due to tailored pre-setting, user interface and **Franklin Electric software**
- Reduced amps
 - ⇒ *Smaller drop lead cross size*
- Higher power density
 - ⇒ *Lightweight*
- Significant lower motor heat rise
 - ⇒ *Increased lifetime*
- Communication Modbus (RS485 and Ethernet)

System Technical Specification:

- Rating: 4 - 30kW
- Power Supply: Voltage 400 - 800V DC (min. starting voltage 440V)
- Frequency 30 - f_N (50 respectively 60Hz)

System Options:

- Plug-in card 6x DI/DO - 308 170 201
- Plug-in card PT100 - 308 170 202
- Plug-in card Profibus - 308 170 203
- Plug-in card 1x AI & 2x AO 308 170 206
- Other voltages
- Sinus output filters in IP54
- PT100 protection
- Motors in 316SS and 904L

Model Numbers Solar System Option

400V High Efficiency Solar System (304SS Motor, VFD & Filter and Flow switch)

P_N [kW]	VFD IP66 & Filter IP54	
	du/dt Filter	Sinus Filter
4,0 - 7,5	308 010 216S	308 010 316S*
9,3 - 11	308 014 223S	308 014 323S*
13 - 18,5	308 014 238S	308 014 338S*
22 - 30	308 016 261S	308 016 361S*

*Non-stock items

For lead length > 120m please consult Franklin Electric

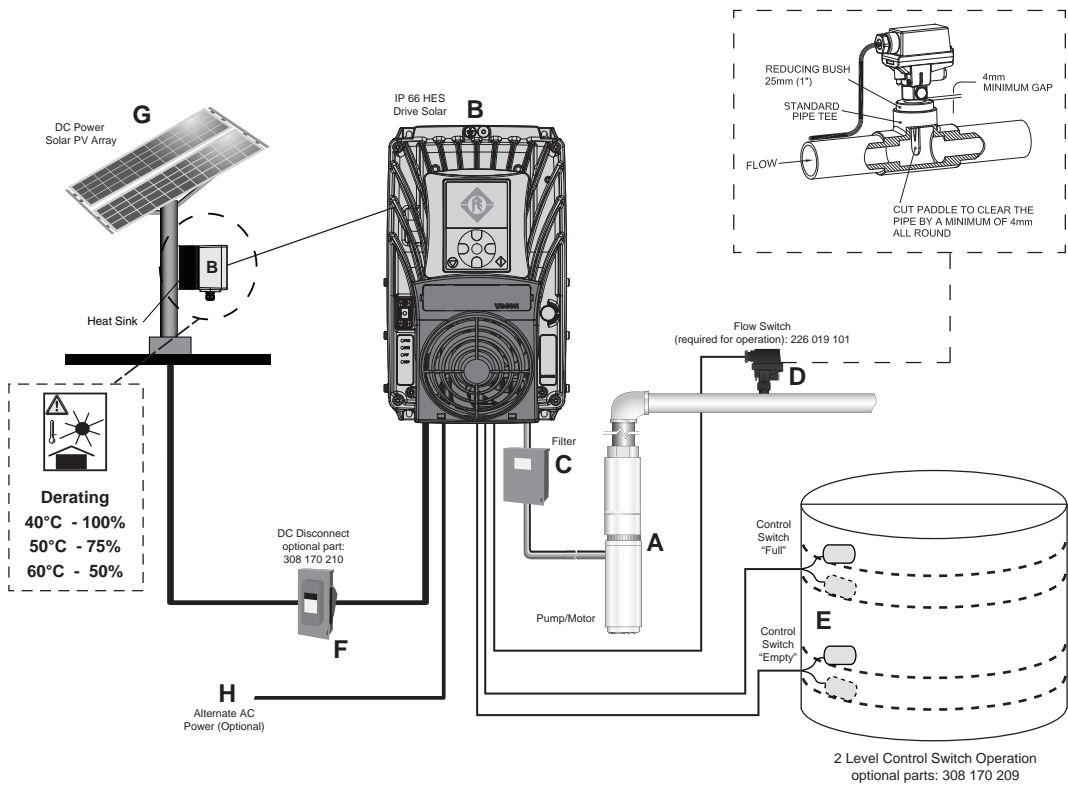

- A. High Efficiency Motor and Pump
- B. IP66 HES Drive Solar
- C. Output Filter
- D. Flow Switch (226 019 101)
- E. Level Control Switch (not included- separate order
308 170 209)
- F. DC Disconnect, not included- separate order:
0 - 11A/800V DC - 308 170 313
12 - 22A/800V DC - 308 170 325
- G. Solar Array (not included)
- H. AC Alternative Power supply (not included)

Control modes and necessary sensor technologies

Process reference	Control reference	Flow meter	Pressure sensor	Level sensor	PT100 sensor & Drive slot card	Flow switch (digital)
Manual Mode	No				Yes*	
Solar	No				Yes*	mandatory

*please consult Franklin Electric



Performance Data 400V-50Hz / 460V/60Hz

400V-50Hz / 460V-60Hz	P_N [kW]	Thrust F [kN]	n_N [min ⁻¹]	I_N [A]	I_A / I_N^* [A]	η [%]	PF [cos ϕ]	T_N [Nm]	T_A / T_N^* [Nm]
308 010 X16	4	15,5	3000 / 3600	8	1	88	0,95	12,9	1
	5,5	15,5	3000 / 3600	10	1	89	0,95	17,5	1
	7,5	15,5	3000 / 3600	13	1	89,5	0,95	23,8	1
308 014 X23	9,3	15,5	3000 / 3600	18	1	91,5	0,95	29,6	1
	11	15,5	3000 / 3600	20	1	92	0,95	35	1
308 014 X38	13	15,5	3000 / 3600	23	1	92,5	0,95	41,5	1
	15	15,5	3000 / 3600	26	1	92,5	0,95	46,1	1
	18,5	15,5	3000 / 3600	32	1	92	0,95	59	1
308 016 X61	22	27,5	3000 / 3600	39	1	93	0,95	70	1
	26	27,5	3000 / 3600	46	1	92,5	0,95	82,6	1
	30	27,5	3000 / 3600	54	1	91,5	0,95	95,5	1
308 016 X87	37	27,5	3000 / 3600	72	1	90	0,95	117,8	1

Performance data are based on measurements with Franklin Electric original equipment!

*Since this is an integrated system (motor plus electronics) these figures relate to VFD input

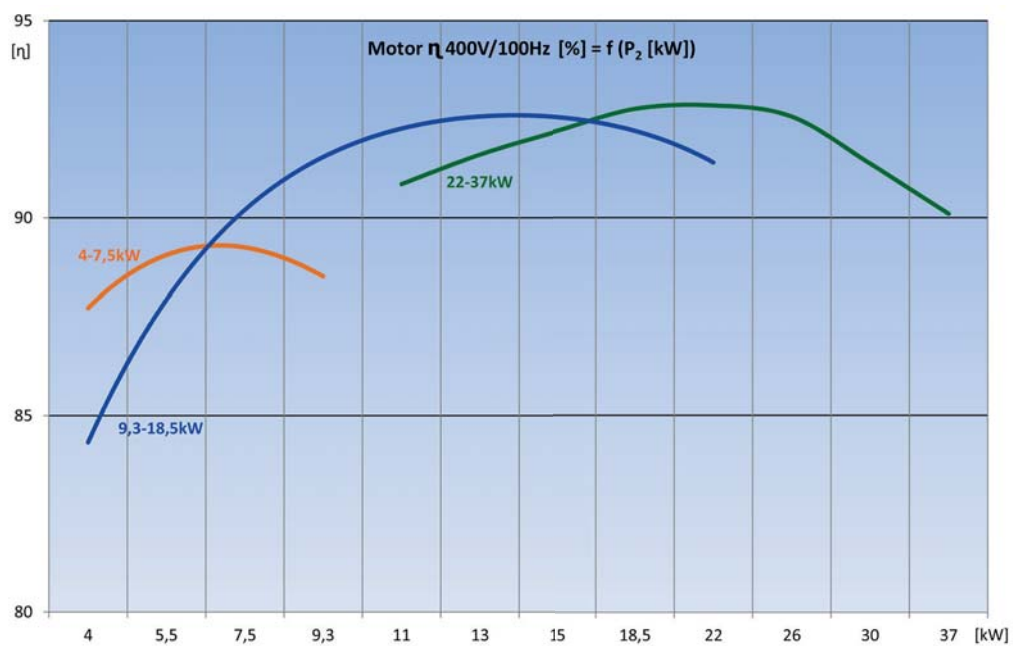

6" High Efficiency Motor



Motor Features:

- Motor complete in 304SS
- PE2/PA winding as a standard
- SandFighter® SIC seal system
- Easy rewinding - winding housings removable
- Non-contaminating FES93 filling
- All motors pre-filled and 100% tested
- Max. storage temperature -15 ... +60°C
- Drinking water approved

Motor Technical Specification:

- 4 – 37kW
- Power supply 400V/100Hz
- 6" NEMA flange with studs (M12)
- Protection IP68
- 20 Starts per hour
- Installation vertical (for horizontal operation please consult FE)
- Motor lead in 4m length
- 30°C nominal ambient temperature with 0,2m/sec cooling flow

Motor Options:

- Other voltages
- PT100 temperature sensor (retrofitable)
 - ⇒ VFD PT100 Plug-in Card (308 170 202) necessary
- Motors complete in 316SS and 904L



System model number	P _N [kW]	Motor model number		
		304SS	316SS	904L
308 010 xxx	4 - 7,5	262 010 8711	262 010 6711	262 010 7711
308 014 xxx	9,3 - 18,5	262 014 8711	262 014 6711	262 014 7711
308 016 xxx	22 - 37	262 016 8711	262 016 6711	262 016 7711



Motor Short Leads*

DOL	P _N [kW]	St.#	∅ [mm²]	H / B [mm]	Length [m]	Lead Mod.- Nr.	Lead seal Kit
	4 - 18,5	1	4G4	8,2 x 23,0	4	308 710 101	308 660 812
	22 - 37	1	4G6	9,0 x 25,0	4	308 710 103	308 660 813

additionally the special Tape **700 541 688** is absolutely necessary

*Cables are designed for submerged operation.

Motor Drop Lead

Lead lengths in meters for 400V-50Hz / 460V-60Hz and max. 3% voltage drop at 50°C ambient

P _N [kW]	cable size mm², copper wire - 90°C rated insulation						
	4	6	10	16	25	35	50
4	160	250	410	-	-	-	-
5,5	140	200	340	530	-	-	-
7,5	100	150	250	390	-	-	-
9,3	75	110	190	300	460	-	-
11	65	100	160	260	400	-	-
13	55	85	140	220	340	460	-
15	-	70	120	190	300	400	-
18,5	-	60	100	160	240	320	440
22	-	-	80	130	200	270	370
26	-	-	65	110	170	230	320
30	-	-	55	90	140	190	270
37	-	-	-	65	100	140	200

For lead length > 120m please consult Franklin Electric.

Further potential energy saving due to more conservative lead sizing (< 3% voltage drop)

Electrical Connection

DOL

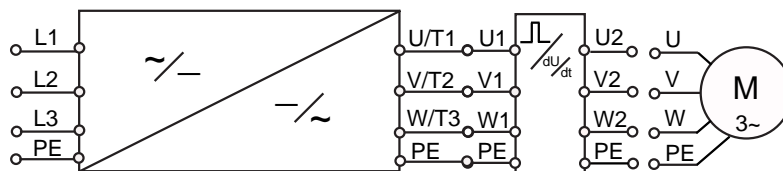

U	V	W	PE
brown	grey	black	yellow/green

Motor Design

304SS / 316SS / 904L

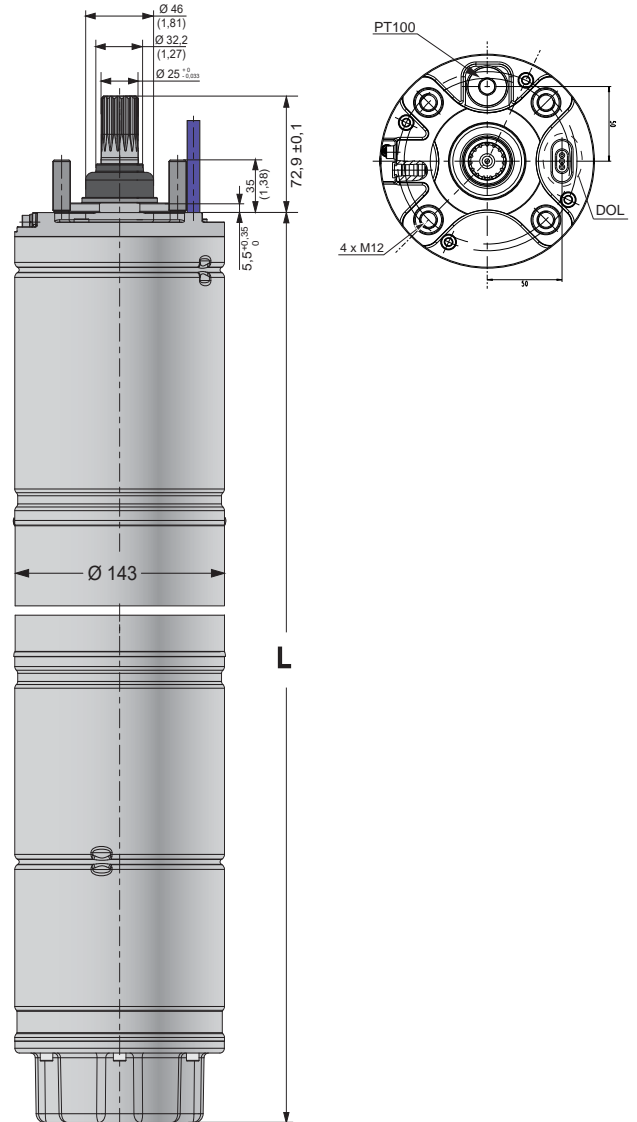

Construction Materials

Component	304SS	316SS	904L
Shaft Extensions	1.4021	1.4462	1.4462
Slinger	NBR	NBR	NBR
Seal	SiC/SiC	SiC/SiC	SiC/SiC
End bell, NEMA	1.4308	1.4408	1.4539
Stator Shell	1.4301	1.4571	1.4539
Diaphragm	EPDM	EPDM	EPDM
Diaphragm Cover	1.4301	1.4404	1.4539

Motor Lengths and Weights

P [kW]	Motor Lengths L [mm]	Motor weights [kg]		Motor Shipping Size		
		Motor	incl. pack	B [mm]	H [mm]	L [mm]
4 - 7,5	655	41	46	155	270	905
9,3 - 18,5	809	56	61	155	270	1135
22 - 37	971	72	77			



Motor Spare Parts 304SS / 316SS / 904L

Kit 1	Thrust Bearing Kit	4-18,5kW	Pos.: 17; 25; 26; 27; 36	308 750 301
		22-37kW		308 750 302
Kit 2	Radial Bearing Kit	4-18,5kW	Pos.: 12; 28	308 750 401
		22-37kW		308 750 403
Kit 3	Seal Kit 304SS / 316SS / 904L	Pos.: 1; 4; 6.1; 15; 17; 20; 34; 42.1, 43		308 800 422
Kit 4	Screw Kit 304SS / 316SS	Pos.: 5; 6; 6.1; 9; 13; 15; 24; 42; 42.1		308 659 325
	Screw Kit 904L	Pos.: 5; 6; 6.1; 9; 13; 15; 24; 42; 42.1		308 659 326
Kit 5	Valve Kit (all Material version)	Pos.: 8; 10		308 800 423
Kit 6	Lead Seal Kit	Pos.: 7		see page 10
Kit 7	PT100 Kit	Pos.: 35		see page 21

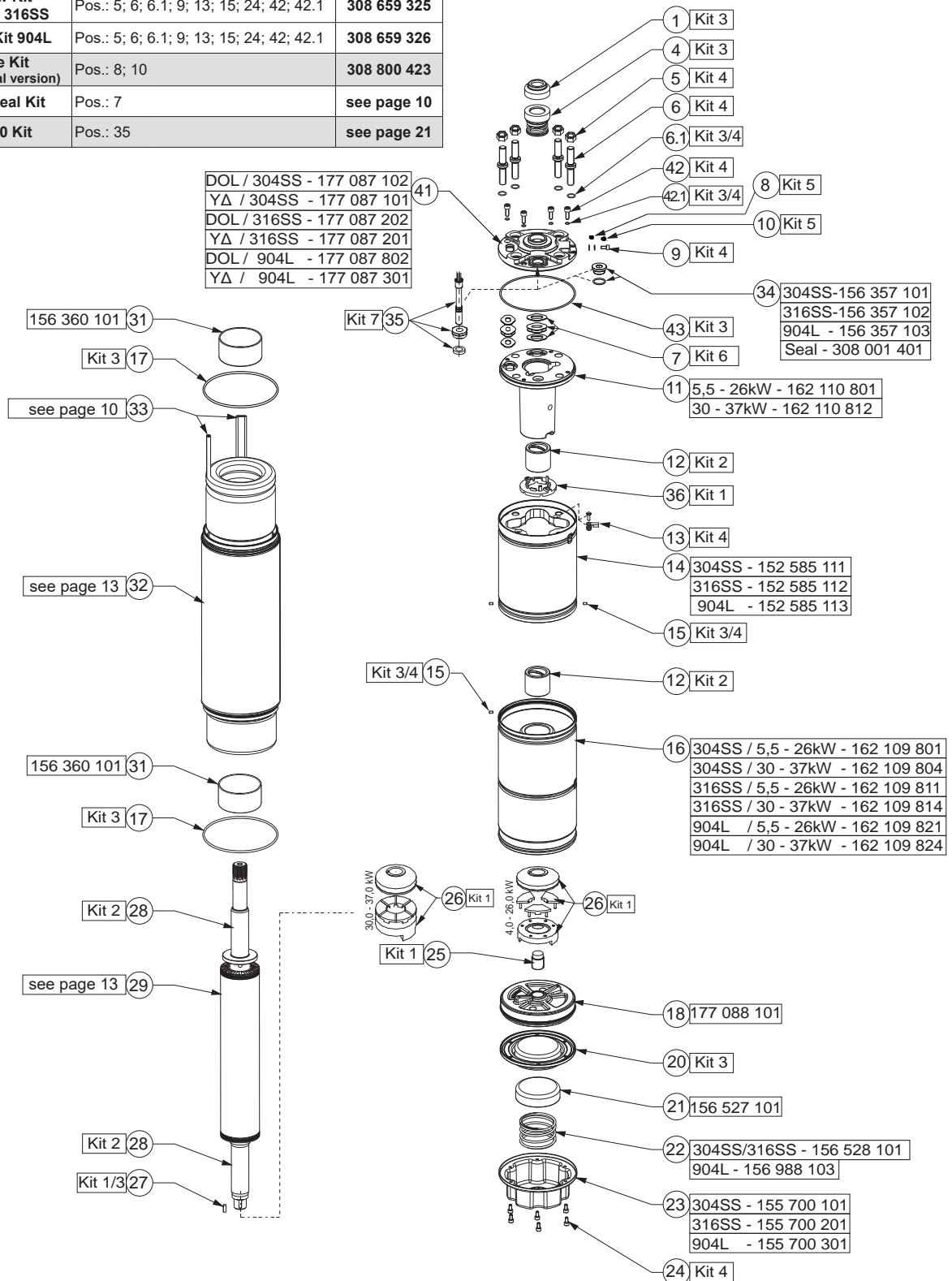

304SS Stator and Rotor Model Number (400V-50Hz / 460V/60Hz)

P_N [kW]	Stator (incl. winding and 4m motor lead)	Rotor
4 - 7,5	327 086 701K	161 122 805K
9,3 - 18,5	327 075 701K	161 122 802K
22 - 37	327 076 701K	161 122 803K

Windings 400V-50Hz / 460V/60Hz

P_N [kW]	Mod.-No. Windingkit	Turns per coil	Wire diameter [mm]	Type of Isolation	Group connection	Total Wire length [m]	Resistance coil [Ω]	Resistance DOL (U1-V1) [Ω]
4 - 7,5	327 086 999	28+28+28+28	1,3 / 2,2	PE2/PA	Serie Y	212	0,2393	1,914
9,3 - 18,5	327 075 999	14+14+14+14	2 / 3,1	PE2/PA	Serie Y	161	0,0794	0,635
22 - 37	327 076 999	18+18+18+18	1,7 / 2,7	PE2/PA	Serie / Parallel Y	276	0,1797	0,359

Insulation resistance (20°C / 500 VDC)

New motor without drop cable	400 >	M Ω
Used motor without drop cable	20 >	M Ω
New motor with drop cable	4 >	M Ω
Used motor with drop cable	1	M Ω

Motor Repair Instructions

Pictured Repair Instructions 304SS / 316SS / 904L	308 018 624
Motor Mounting Kit	308 239 214



Variable Speed Drive (VFD)



VFD Features:

- Supports induction and permanent magnet motors
- Top class protection IP66 with Aluminium die casting powder coated enclosure . Alternative in IP21 with plastic enclosure
- Optimized for submersible permanent motor feeding – first class performance (Tailored pre-setting, user interface and software)

VFD Technical Specification:

Power supply	Input voltage U_{IN}	380 - 500V ; -10%....+10% 400 - 840V DC - min starting voltage 440V
	Input frequency f_{IN}	47 - 65Hz
	Starts per hour	20 ; with min 3min rest period
Motor connection	Output voltage	0 - U_N
	Output current	I_N at rated Ambient temperature (40°C) Overload: IP66: 1,5 x I_N (1min/10min) IP21: 1,1 x I_N
	Output frequency	0- f_N , resolution 0,01Hz
Performance	Efficiency	97,5%
Control characteristics	Switching frequency	3,6 6 kHz; default setting 4 kHz
Ambient conditions	Operation temperature	-10°C...+50°C (>40°C with derating) - 40°C optional for IP66
	Storage temperature	-40°C+70°C
	Altitude	3000m (>1000m with derating)
EMC	Immunity & Emissions	Complies with EN 61800-3, Category C2 - first and second environment
Communication	RS 485	Standard: Modbus
	Ethernet	Standard: Modbus
I/O connections	Digital Input (DI)	6x
	Analog Input (AI)	2x
	Analog Output (AO)	1x
	Relay Output (RO)	2x (change-over contact)
For further details please see separate Franklin Electric Quick Installation guide and VFD literature.		

VFD Model Numbers and Dimensions 400V-50Hz / 460V/60Hz

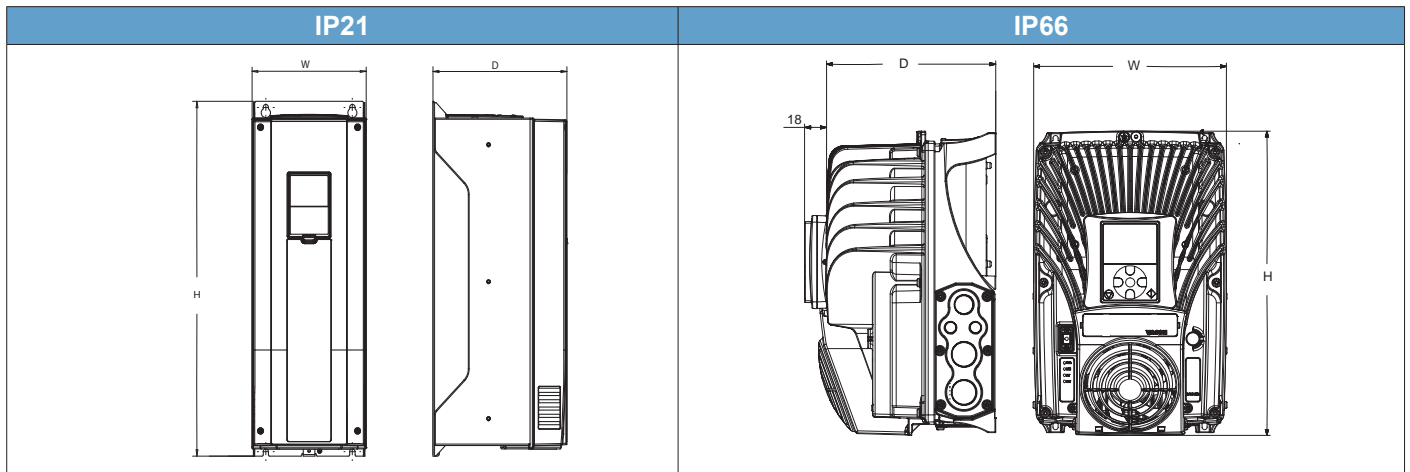

VFD High Efficiency System Model Numbers and Dimensions 400V-50Hz / 460V/60Hz IP21 up to 37kW

System Model Number	AC Drive Type	IP Type	I_N [A]	Dimensions WxHxD [mm]	Weight [kg]
308 010 016/116	314 000 108	21	16	144 x 419 x 214	10,0
308 014 023/123	314 000 101	21	23	144 x 419 x 214	10,0
308 014 038/138	314 000 102	21	38	195 x 557 x 229	20,0
308 016 061/161	314 000 103	21	61	195 x 557 x 229	20,0
308 016 087/187	314 000 104	21	87	237 x 660 x 259	37,5

VFD High Efficiency System 400V-50Hz / 460V/60Hz IP66 up to 30kW

System Model Number	AC Drive Type	IP Type	I_N [A]	Dimensions WxHxD [mm]	Weight [kg]
308 010 216/316	314 000 109	66	16	233 x 368 x 214	14,9
308 014 223/323	314 000 105	66	23	233 x 368 x 214	14,9
308 014 238/338	314 000 106	66	38	350 x 500 x 236	31,5
308 016 261/361	314 000 107	66	61	350 x 500 x 236	31,5

VFD Options:

- 200V - 230V
- Plug-in card 6x DI/DO 308 170 201
- Plug-in card PT100 308 170 202
- Plug-in card Profibus 308 170 203
- Plug-in card 1x AI & 2x AO 308 170 206
- Replacement Battery VFD IP21 - 308 170 205
- Replacement Battery VFD IP66 - 308 170 204



Output Filter

Output Filter Features:

- du/dt filter for lead lengths up to 120m, for lead lengths >120m please consult Franklin Electric.
- filter available in IP54 and IP00
- Optimized for submersible permanent magnet motor feeding

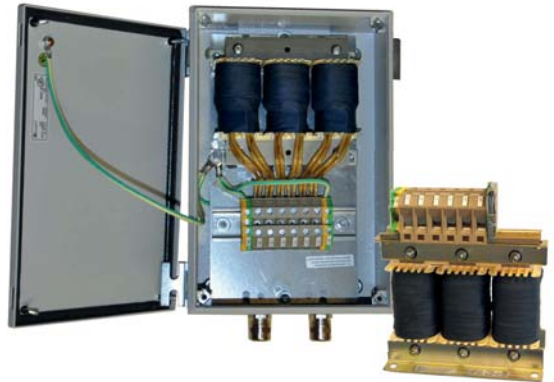

Output Filter Technical Specification:

- Voltage → 380 - 500V
- Frequency → 0 - 120 Hz
- Switching Frequency → 4kHz
- Ambient Temperature → < 40°C

Output Filter Options:

- Sinus filter in IP54 and IP00 for lead length >120m and/ or special applications
- Other voltages

Output Filter dV/dt High Efficiency System 400/500V Model Data - Protection Class IP00*

System model number	Filter order code	I _N [A]	Dimensions [mm]							weight [kg]	terminal		clamping torque	
			a	b	c	n1	n2	d	e		main [mm ²]	PE [mm ²]	main [Nm]	PE [Nm]
308 010 016 308 014 023	314 005 101	24	125	92	161	55	100	5	15	2,5	1,5 - 16	1,5 - 16	2,5 - 3	2,5 - 3
308 014 038	314 005 102	38	155	96	197	56	130	8	20	4	1,5 - 35	1,5 - 35	3,2 - 3,7	3,2 - 3,7
308 016 061	314 005 103	62	155	105	197	65	130	8	25	5	1,5 - 35	1,5 - 35	3,2 - 3,7	3,2 - 3,7
308 016 087	314 005 104	88	190	116	238	67	170	8	30	8	25 - 50	M10	6 - 8	46 - 50

Output Filter dV/dt High Efficiency System 400/500V Model Data - Protection Class IP54*

System model number	Filter order code	I _N [A]	Dimensions [mm]						cable Ø [mm]	weight [kg]	terminal		clamping torque	
			a	b	c	e	f	main [mm ²]			PE [mm ²]	main [Nm]	PE [Nm]	
308 010 216 308 014 223	314 005 110	24	325	354	227	242	330	2x23-33,5	10	1,5 - 16	1,5 - 16	2,5 - 3	2,5 - 3	
308 014 238	314 005 111	38	325	354	227	242	330	2x23-33,5	12	1,5 - 35	1,5 - 35	3,2 - 3,7	3,2 - 3,7	
308 016 261	314 005 112	62	325	354	227	242	330	2x29-40	18	1,5 - 35	1,5 - 35	3,2 - 3,7	3,2 - 3,7	

IP00 dV/dt Filter - Outlines

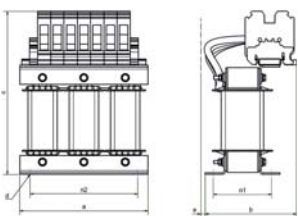

IP54 dV/dt Filter - Outlines

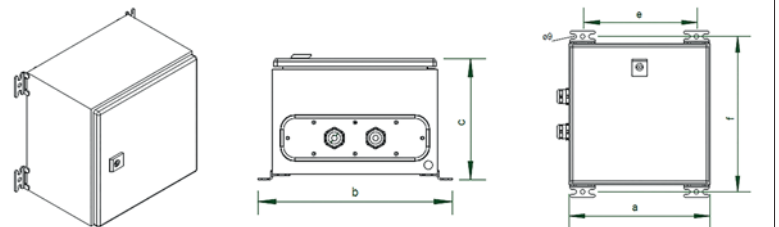

*By changing the supplier it can be differentiated with the dimensions!

dV/dt Filter - Connection Plan

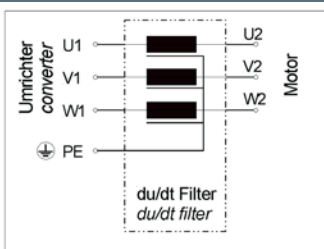

Output Filter Sinus High Efficiency System 400/500V Model Data - Protection Class IP00*

System model number	Filter order code	I _N [A]	Dimensions** [mm]						weight [kg]	terminal		clamping torque	
			a	b	c	n1	n2	d		main	PE	main	PE
										[mm ²]	[mm ²]	[Nm]	[Nm]
308 010 116	314 005 105	16	240	188	285	75	185	10	18	1,5 - 35	1,5 - 35	3,2 - 3,7	3,2 - 3,7
308 014 123/131	314 005 106	31	240	208	285	95	185	10	27	1,5 - 35	1,5 - 35	3,2 - 3,7	3,2 - 3,7
308 014 138/146	314 005 107	46	300	222	351	131	250	10	34	25 - 50	25 - 50	6 - 8	23 - 25
308 016 161	314 005 108	72	360	276	410	127	264	10	56	25 - 50	25 - 50	6 - 8	23 - 25
308 016 187	314 005 109	105	360	276	413	127	264	10	57	35 - 95	M10	15 - 20	46 - 50

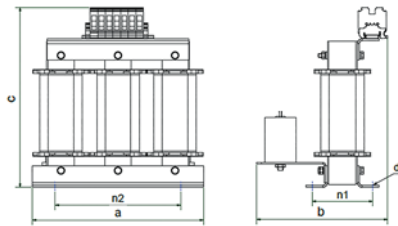
Filter outlines

Output Filter Sinus High Efficiency System 400/500V Model Data - Protection Class IP54*

System model number	Filter order code	I _N [A]	Dimensions** [mm]						cable Ø [mm]	weight [kg]	terminal		clamping torque	
			a	b	c	e	f	main			PE	main	PE	
								[mm ²]			[mm ²]	[Nm]	[Nm]	
308 010 316	314 005 117	16	600	435	230	542	410	2x23-33,5	49	1,5 - 35	1,5 - 35	3,2 - 3,7	3,2 - 3,7	
308 014 323*	314 005 113	23	550	560	550	185	520	2x23-33,5	56	1,5 - 35	1,5 - 35	3,2 - 3,7	3,2 - 3,7	
308 014 338*	314 005 115	38	770	610	620	450	570	2x23-33,5	65	25 - 50	25 - 50	6 - 8	23 - 25	
308 016 361*	314 005 116	72	770	610	620	450	570	2x35-46	112	25 - 50	25 - 50	6 - 8	23 - 25	

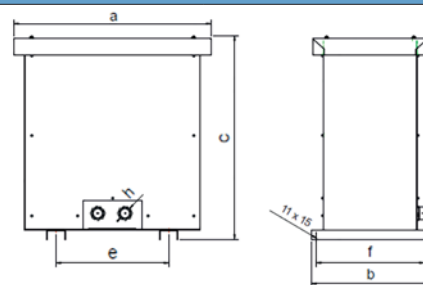
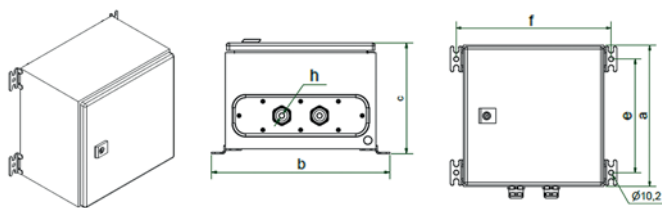
*Floor mount

Wall mount outlines
Floor mount outlines

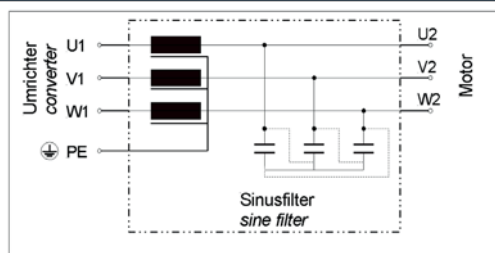
**By changing the supplier it can be differentiated with the dimensions!

Filter Connection Plan



SS Pump

For any pump support please refer to:
<http://franklinwater.eu/products/>



Lead Termination Kit 1,5 - 10mm²

- 4 wire
- 1,5 - 10mm²
- up to 1,2kV

Part number: 308 090 921



Motor Filling Liquid

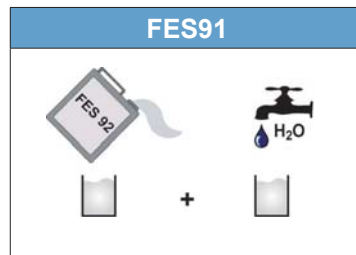

**Part number:
308 353 941**

Motor Filling Kit

This kit contains all necessary tools to check and replenish Franklin Electric submersible motors with FES 91, 92 or 93 filling liquid (fill solution/concentrate must be ordered separately).



Part number: 308 726 103



Motor/Pump Couplings

Application

Franklin Electric offers this line of motor-pump couplings for maximum customer convenience in matching the Franklin motor to a variety of pump shafts. Couplings are designed to transmit the pump thrust to the motor in order to provide maximum benefits from the Franklin internal thrust bearing construction.

Hardened stainless steel spacer discs in the 6" couplings assure positive bearing between motor and pump shafts, and assure full support for downward thrust created by the pump.



6" Motor – Pump Couplings

Application:

Allow connection of pump to motors shaft.

Specification:

- Material: 304 / 316 SS
- NEMA standard measuring on motor shaft
- separation washer between motor & pump shafts

Outline Drawing:

6" Couplings

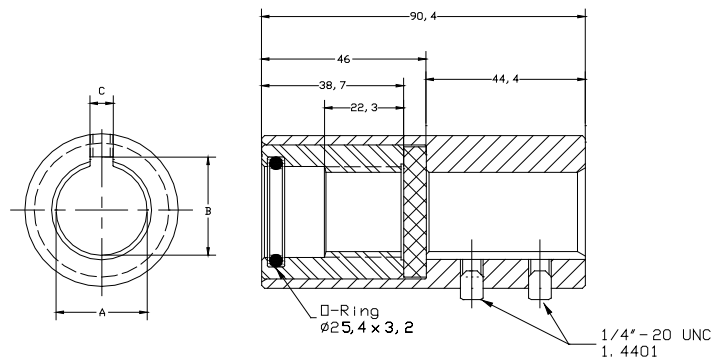

Ordering information

No.	Coupling Material DIN / AISI	Dimension A (mm) Max. / Min.	Dimension B (mm) Max. / Min.	Dimension C (mm) Max. / Min.
151 935 902	1.4005 (304)	19,075 / 19,063	20,70 / 20,52	4,84 / 4,79
151 935 922	1.4401 (316SS)			
151 935 910	1.4005 (304)	20,025 / 20, 013	22,76 / 22,60	6,05 / 6,00
151 935 927	1.4401 (316SS)			
151 935 908	1.4005 (304)	22,025 / 22,013	25,53 / 25,32	8,03 / 7,98
151 935 928	1.4401 (316SS)			
151 935 901	1.4005 (304)	22,250 / 22,238	24,54 / 24,36	6,43 / 6,38
151 935 921	1.4401 (316SS)			
151 935 906	1.4005 (304)	25,025 / 25, 013	28,70 / 28,30	8,03 / 7,98
151 935 926	1.4401 (316SS)			
151 935 909	1.4005 (304)	25,425 / 25,413	27,74 / 27,56	6,43 / 6,38
151 935 929	1.4401 (316SS)			

PT100 Rewindable Motors

Application

- Can be fitted to the upper motor flange of any FE Rewindable motor
- Measures the temperature of the filling liquid
- Conductor with a resistance proportional to the temperature
- Allows continuous temperature monitoring

The above-ground equipment is not available from Franklin Electric and is typically part of a custom panel or data acquisition system. PT100 sensor retrofit kits from Franklin Electric come with complete instructions and allow for easy field installation.

VFD PT100 Plug-in Card (308 170 202) necessary

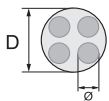

	Ø [mm ²]	D [mm]	Lead Lengths [m]		304/316	904L
PT 100	4X0,5	8	10	Mod.- No.:	308 016 501	308 016 522
PT 100	4X0,5	8	20	Mod.- No.:	308 016 502	-
PT 100	4X0,5	8	30	Mod.- No.:	308 016 503	-
PT 100	4X0,5	8	50	Mod.- No.:	308 016 505	308 016 526

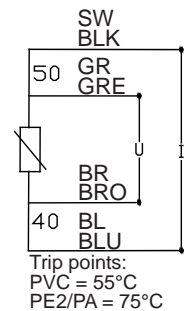

Flow Paddle Switch

The flow switch utilizes the force of liquid flow to propel its paddle and to detect the incoming flow or movement of the existing liquid in the pipe. A required Part of the 6" High Efficiency Solar System.

Mod.Nb.: 226 019 101



Inline Flow Switch

The Inline Flow Switch operates magnetically. The piston within the switch body should be a free fit and spring back to its off position as soon as flow stops. A required Part of the 6" High Efficiency Solar System.

Mod.Nb.: 226 014 101



Level Switch

A float switch is a device used to detect the level of liquid within a tank. A required Part of the 6" High Efficiency Solar System.

Mod.Nb.: 308 170 209



DC Disconnect

To disconnect the drive even under load safely from the solar generator, Franklin Electric offers suitable DC disconnect switches for all different power ratings.

0 - 11A/800V DC - 308 170 313

12 - 22A/800V DC - 308 170 325





Franklin Electric

Franklin Electric Europa GmbH
Rudolf Diesel Strasse 20
54516 Wittlich / Germany

franklinwater.eu

DOC.NB. 308-018-647EN REV. 14 08-17